

Formatic - DD12,000

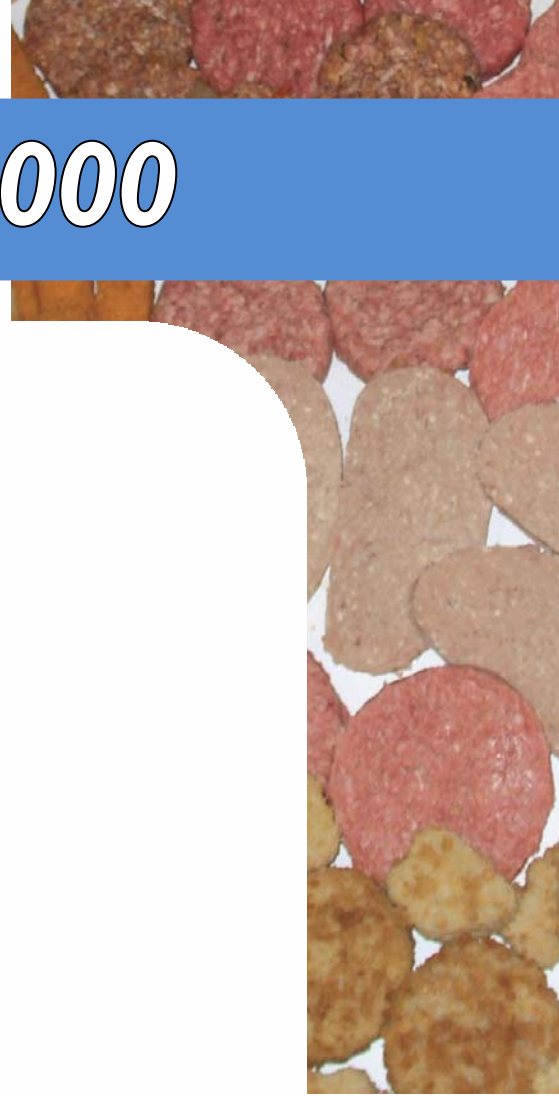

The Formatic range of machines from Deighton Manufacturing (UK) Ltd are the perfect solution to your food forming and portioning requirements.

Able to form a wide range of products including meat, fish, potato, vegetable & ethnic, butter & cheese as well as bakery and confectionary, into a variety of shapes and sizes, the **Formatic** is the industry standard for small to high volume food producers.

The DD12,000 is the top of the range model and can produce forms up to 135mm diameter at a rate of 12,000 drops per hour.

DEIGHTON

innovative food processing

Technical Specification

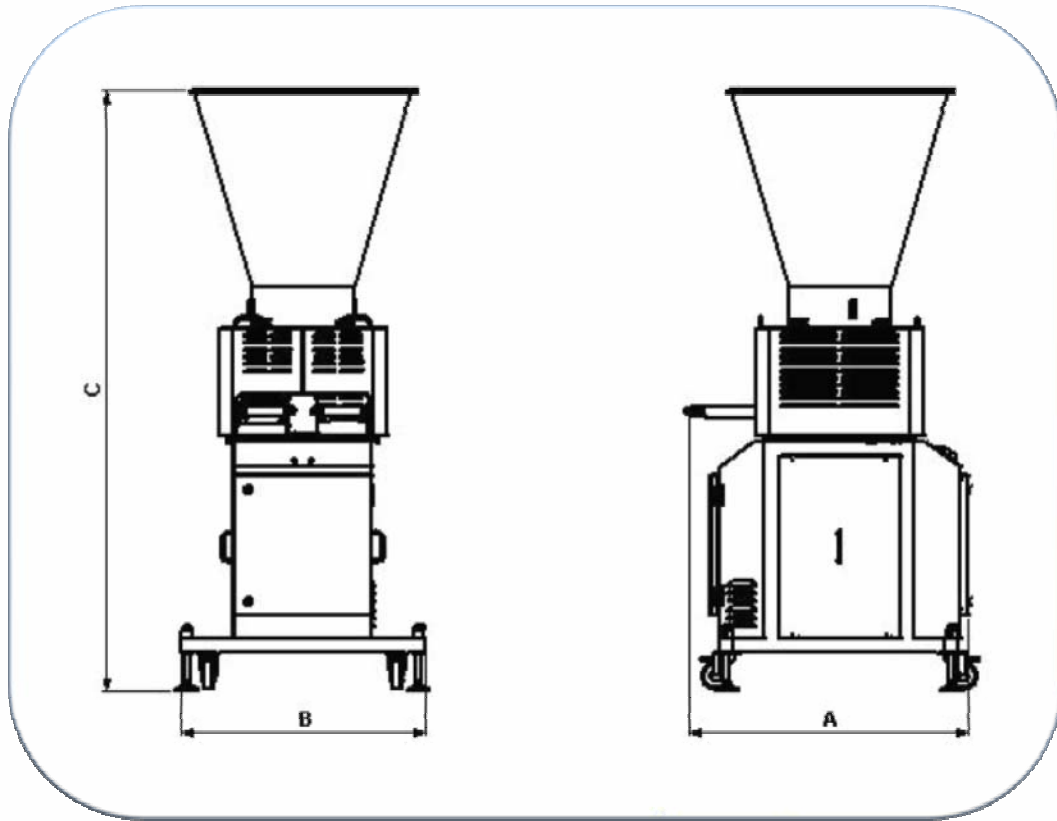

Machine	Length (A)	Width (B)	Height (C)	Weight	Power	Electricity Supply	Hopper Capacity	Output
DD12,000	1003mm	880mm	2145mm	220Kg	1750w	220/240v	200Lt	12,000/hr

www.deightonmanufacturing.co.uk
sales@deightonmanufacturing.co.uk

DEIGHTON

Deighton Manufacturing (UK) Ltd,
Gibson Street, Leeds Road, Bradford, England BD3 9TR
Tel: +44 (0)1274 668771 Fax: +44 (0)1274 665214

innovative food processing