



## An Industry Leading Cookie and Food Forming Machine!

The Formatic is a wire-release cookie machine capable of processing doughs with large inclusions. The entry-level R1200 can achieve speeds of up to 1,200 revolutions per hour. Their unique drum system also facilitates the production of cookies with a variety of different shapes, as well as varying thicknesses.



### Features

- ✓ **Versatility**  
*This cookie machine is also used to form granola bars, protein bars, scones, biscuits, dog treats, and other baking/confectionery products.*
- ✓ **Simple & Easy Operation**  
*This machine is easy to use and clean!*
- ✓ **Accurate Portion Control**  
*Consistent results (weight and size) with each deposit. Weight can also be modified via thickness adjustments.*
- ✓ **Adjustable Thickness**  
*Deposit thickness ranges from as thin as your product will allow – 0.75 inches (19 mm).*
- ✓ **High Volume Production**  
*Models capable of reaching high volume production*
- ✓ **Interchangeable Drums**  
*Deposit a wide variety of cookie types and shapes with an assortment of drum options.*
- ✓ **Manual & Automatic Operation**  
*Choose between manual, foot pedal-based operation or continuous, automatic depositing.*

### Available Options

- + **Automatic Wire Cleaning**  
*Attachment designed to automatically scrape the wire-release mechanism after each deposit.*
- + **Automatic Papering**  
*Attachment designed to automatically place product onto paper with each deposit.*
- + **Additional Drums**  
*Purchase additional drums that can be interchanged for a diverse product lineup.*
- + **Various Hopper Sizes**  
*Larger hoppers are available for large-scale production.*
- + **Extended Conveyors**  
*Longer conveyor belts are available upon request.*
- + **Deep Drop Drum**  
*Achieve deposits with thickness ranging between 0.25 inches (7 mm) – 1.25 inches (32 mm).*

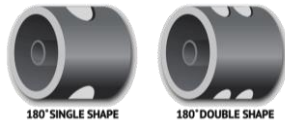



## Custom Drum Shapes

We can produce custom drums using a wide variety of different shapes within a 4" x 4" (101 x 101 mm) area. This includes the ability to fit multiple shapes on a single drum.



## Technical Specifications

	R1200	R2200	R3000
<b>Electrical Specifications</b>	110 v   1ph   60 Hz	220v   3 ph   60 Hz	
<b>Machine</b>	0.75 kW	1.1 kW	1.5 kW
<b>Hopper Capacity</b>	25 lb.   11.5 kg		45 lb.   20.5 kg
<b>Output (Revolutions/Hour)</b>	1,200	2,200	3,000
<b>Production Rate</b>	1,200 - 2,400/hour	2,200 - 4,400/hour	3,000 - 6,000/hour
<b>Warranty</b>	1 year parts   90 days labor		
<b>Certifications</b>	BEAG & UL		
<i>Standard Dimensions (A x B x C)</i>			
<b>Standard Dimensions</b>	42 x 35 x 36"   1062 x 889 x 915 mm	42 x 36 x 36"   1062 x 915 x 915 mm	45 x 36 x 42"   1143 x 915 x 1062 mm
<b>Net Weight</b>	241 lb.   109 kg	254 lb.   115 kg	267 lb.   121 kg
<i>Shipping Dimensions (L x W x H)</i>			
<b>Shipping Dimensions</b>	36 x 29 x 44"	36 x 29 x 46"   915 x 737 x 1169 mm	
<b>Shipping Weight</b>	265 lb.   120 kg	278 lb.   126 kg	291 lb.   132 kg

## Accessories

*Formatic table for easier storage and portability*



## Approvals





ERIKA RECORD  
BAKING EQUIPMENT

DEIGHTON

800.682.8203  
www.erikarecord.com

Deighton | Formatic R-Series Wire-Release Cookie Machine



### Technical Drawings

R1200 & R2200

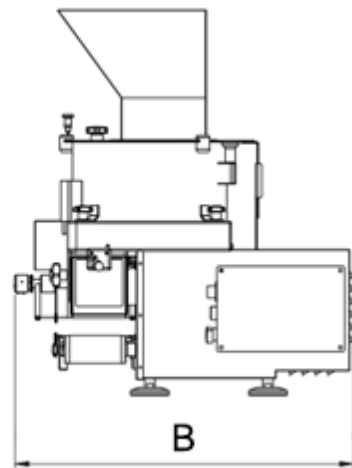
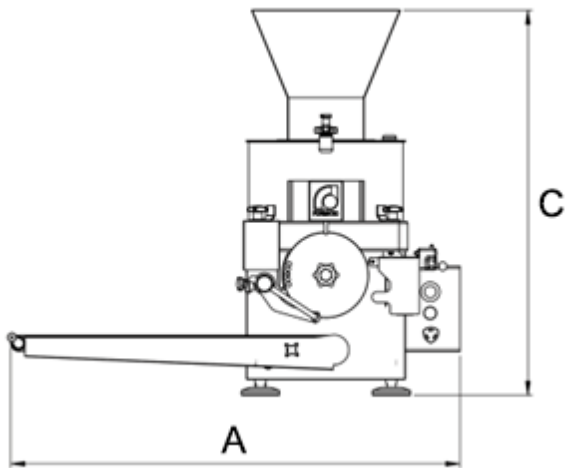

R3000

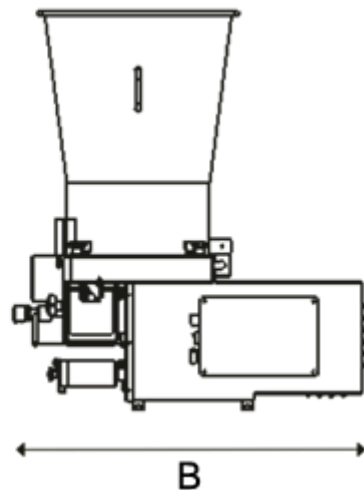
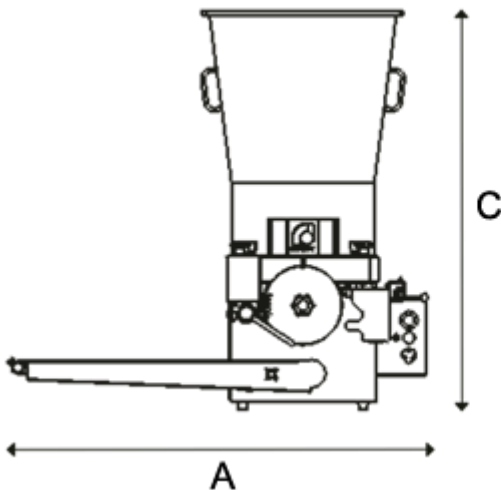



**ERIKA RECORD**  
BAKING EQUIPMENT

**DEIGHTON**

**800.682.8203**  
[www.erikarecord.com](http://www.erikarecord.com)

**Deighton | Formatic R-Series Wire-Release Cookie Machine**

**Notes:**

---



---



---



---



---



---



---



---



---



---



---



---



---



---



---



---



---



---



---



---



---



---

**ACCESS OUR  
PRODUCT PAGE & VIDEO**



*Specifications are subject to change without notice, as we remain committed to delivering the best equipment possible. Technical specifications and warranty information will be provided in your quote.*